

**Diesel Fuel Manager®...
Quality and Purity You Can Count On**



Designed to remove water and particulate contaminants without impeding fuel flow, the Fuel Manager® system combines the function of traditional water separators and filters into one customizable unit.

The latest water-repelling, high efficiency media and your choice of optional, modular components ensure maximum life and performance from your diesel engine.

Donaldson®

Everything you need AND only what you need!

Donaldson Fuel Manager[®] Diesel Fuel Filter/Water Separator

The fuel filtration and water separation needs of today's new generation of diesel fuel systems demand extremely high efficiency, flexibility, multiple functions and ease-of-use with no risk of fuel spills or contaminated parts. Donaldson Fuel Manager fuel filter/water separators meet these demanding requirements.

- **Application:** designed for 350-650 HP diesel engines - trucks and buses
- **Media:** specially-treated hydrophobic media removes both water and particulate
- **Mounting flexibility:** chassis, frame or engine mounted
- **Maximum fuel flow:** 180 gph / 680 lph
- **Typical pressure drop:** 0.8 psi (5kPa) at 45 gph / 170 lph
- **Operating temperature:** -40°F to 250°F (-40°C to 121°C)
- **Filter media micron ratings:** choice of 2, 5 or 30 micron
- **“Key Track” System:** non-threaded filter connection ensures correct service filter is installed; no-spill, tool-free filter change
- **Optional Modular Components:** easily custom-configure your system to meet your specific needs

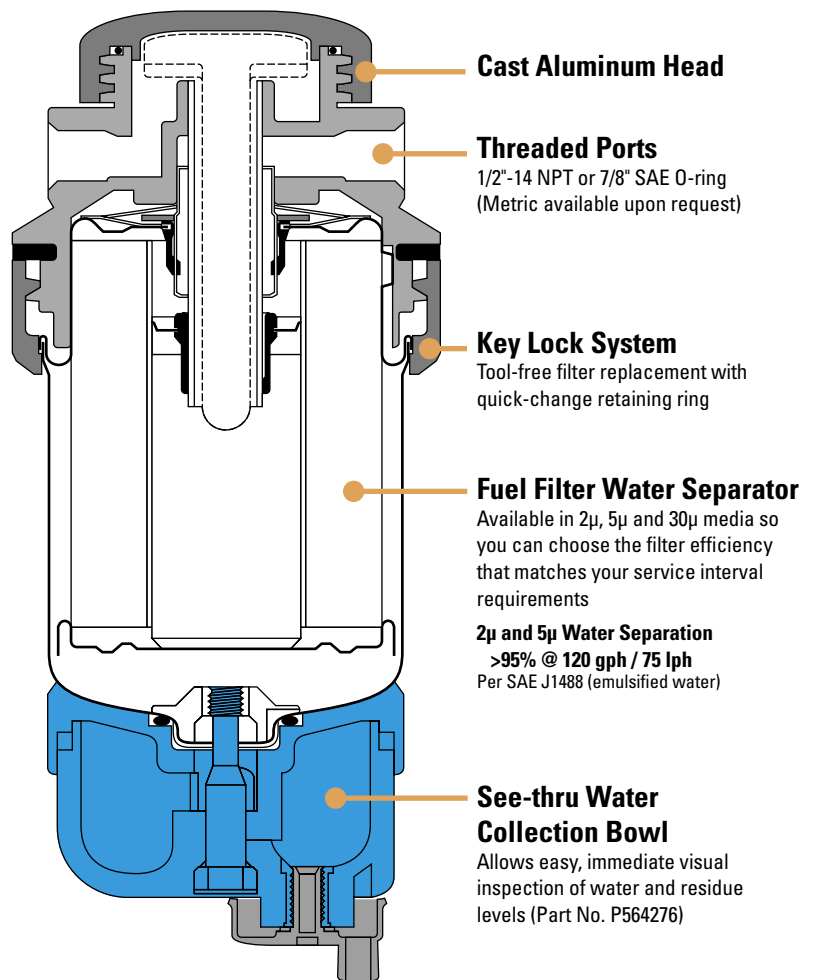

The Versatile Fuel Filtration System

Your filtration requirements change depending on your needs, your location and your engine. Available for diesel truck and bus engines, the Donaldson Fuel Manager can be easily configured to match *any* operating condition.



Optional Components

The Donaldson Fuel Manager is completely modular. Start with the base system and add or remove optional components without disconnecting fuel lines, allowing your system to be easily custom-configured.

Water-in-Fuel Sensor

- 12 volt sensor (24 volt available upon request)
- connected from filter's sump to remote alert light
- electronic module signals when water needs to be drained
- ideal for applications where see-thru bowl is not visible
- Part No. P564277

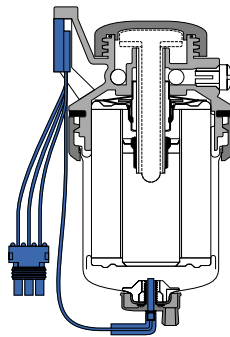

Thermal Diverter Valve Heater

- electric heater prevents fuel waxing and significantly improves cold weather operation
- hot fuel is immediately delivered through a filter tee in the return line when you turn the key
- requires a custom head – must be ordered as a separate assembly (K031008)

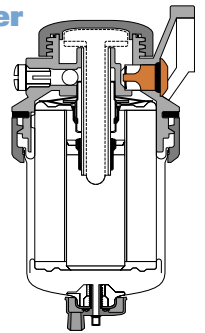

Hand Primer Pump

- quickly purges air from the fuel system after a filter change
- maintains flow integrity on vacuum-side filter applications
- Part No. P564281

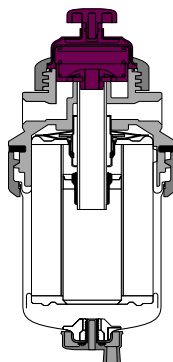

Side-Load Heater

- 12 volt, 200 watt (24 volt available upon request)
- contains an integral thermal switch
- Part No. P564280

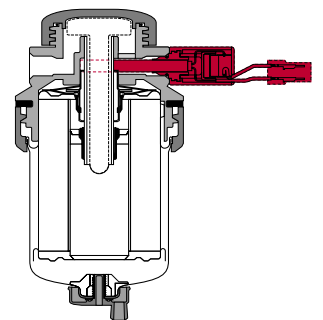

Fuel Manager® Assembly Dimensions

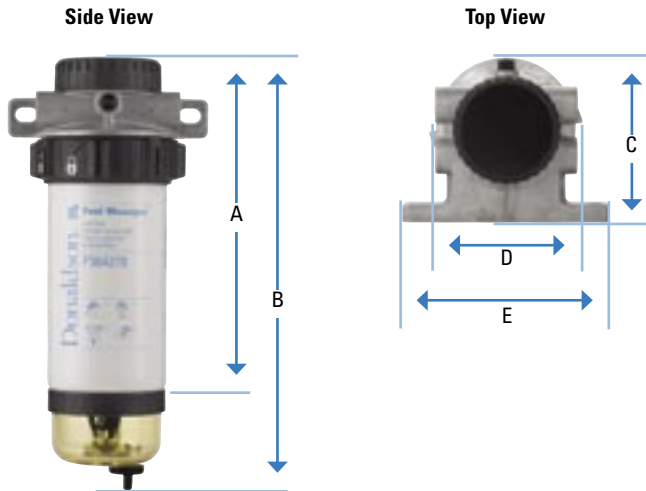

Fuel Manager® Assembly Dimensions

Assembly Number	Filter Number	Filter Length	Micron Rating	Port	A	B	C	D	E	Service Clearance
K031011	P564393	4.0" 102mm	2	7/8" O-ring	8.8" 224mm	12.6" 321mm	6.1" 155mm	5.6" 142mm	7.4" 188mm	2.1" 53mm
K031010	P564392	8.0" 203mm	2	7/8" O-ring	12.8" 325mm	16.6" 422mm	6.1" 155mm	5.6" 142mm	7.4" 188mm	2.1" 53mm
K031006	P564278	8.0" 203mm	5	7/8" O-ring	12.8" 325mm	16.6" 422mm	6.1" 155mm	5.6" 142mm	7.4" 188mm	2.1" 53mm
K031005	P564278	8.0" 203mm	5	1/2" NPT	12.8" 325mm	16.6" 422mm	6.1" 155mm	5.6" 142mm	7.4" 188mm	2.1" 53mm
K031008 ¹	P564278	8.0" 203mm	5	1/2" NPT	12.8" 325mm	16.6" 422mm	6.1" 155mm	5.6" 142mm	7.4" 188mm	2.1" 53mm
K031012	P564430	8.0" 203mm	30	1/2" NPT	12.8" 325mm	16.6" 422mm	6.1" 155mm	5.6" 142mm	7.4" 188mm	2.1" 53mm

1 - Mounting head includes Thermal Diverter Valve Heater
 Fuel Manager is a registered trademark of Stanadyne Corporation.



Donaldson®

Donaldson Company, Inc.
 Minneapolis, MN
 55440-1299

www.donaldson.com

Brochure No. F111165 (4/05)

© 2005 Printed in the U.S.A.
 Equal Opportunity Employer
 Donaldson Company, Inc. reserves the
 right to change or discontinue any model or
 specification at any time and without notice.

North & South America
 800-374-1374

Europe & Middle East
 32-16-38-3811

Asia Pacific
 65-6311-7373

South Africa
 27-11-389-8800

Australia
 612-4350-2033